

SHARP

415W / NU-JC 415B

Mono-crystalline PERC Half-Cell Module

Sharp Solar.
The sun is the answer.



Sharp, leader in the solar industry: Shipping more than 17.0 GW globally
Experience in PV technology since 1959



We select the materials based on what we have learned over the past 6 decades of making modules and validate our choices with rigorous testing that goes well beyond standard test protocols established by IEC. We have selected high efficiency monocrystalline cells to give you more power and more energy per square meter.

Our warranties are based on real history of past installations beyond the timespans stipulated.

Using breakthrough technology, made possible by over 60 years of proprietary research and development, Sharp's solar modules incorporate an advanced surface texturing process to increase light absorption and improve efficiency.

Common applications include commercial and residential grid-tied roof systems as well as ground mounted arrays. Designed to withstand rigorous operating conditions, this module offers high power output per square meter of solar array.

**RESIDENTIAL PURPOSE
415 WATT MONOCRYSTALLINE
MODULE FROM THE WORLD'S
TRUSTED SOURCE FOR SOLAR.**

Product features

- ◆ **Positive Power Tolerance :**
Production controlled positive power binning (+5W/-0W)
Only modules will be delivered that have the specified power or more for high energy yield.
- ◆ **High-performance photovoltaic modules:**
Made of mono-crystalline PERC Half-Cells with module efficiencies of up to 21.25%.
- ◆ **Guarantee:**
25 years Linear power output guarantee
25 years* Product guarantee
*Applicable for modules installed in Australia for residential use. Please check the guarantee conditions for the details.
- ◆ 10 busbars technology for enhancing the power output

MECHANICAL DATA

Cells	182x91mm (Typ.), mono crystalline silicon
No. of Cell (connections)	108 pcs. (54 series cells in parallel)
Dimensions (LxWxD)	1,722x1,134x30mm
Weight	20.7kg
Frame	Anodized aluminum alloy (Color : Black)
Glass	Low iron tempered glass
Back sheet	Weatherproof film (Color : White)
Junction Box	IP-rating 68 (at live parts with the silicone potting)
Cable	H1Z2Z2-K or 62930 IEC131 cable 4.0mm square Length : 1250±50mm
Connector	PV-KST4, PV-KBT4, Stäubli Electrical
Fire Rating	Class C

415W / NU-JC 415B



Electrical data (at STC*)

Maximum power (±3%)	Pmax	415	Wp
Power binning (+5W/-0W)			
Open-circuit voltage (±3%)	Voc	38.08	V
Short-circuit current (±5%)	Isc	13.87	A
Voltage at point of maximum power	Vmpp	31.49	V
Current at point of maximum power	Impp	13.18	A
Module efficiency	ηm	21.25	%

STC = Standard Test Conditions: Irradiance 1,000 W/m², AM 1.5, cell temperature 25 °C

Tolerance of Pmax = The power measurement uncertainty of the testing equipment shall be considered to all actual power output measurements when to evaluate the warranted performance.

Limit values

Maximum system voltage	1,000 VDC
Over-current protection	25A
Temperature range	-40 to +85 °C
Max. mechanical test load	2,400 Pa
Tested snow load	5,400 Pa

(IEC 61215 test pass*)

Standards and Certification

- * IEC 61215 : 2021
- * IEC 61730 : 2023

Country of Manufacture

China

Temperature coefficient

Pmax	-0.341% / °C
Voc	-0.262% / °C
Isc	+0.054% / °C

Certificate Holder

Sharp Solar Solution Asia Co., Ltd

Rear view

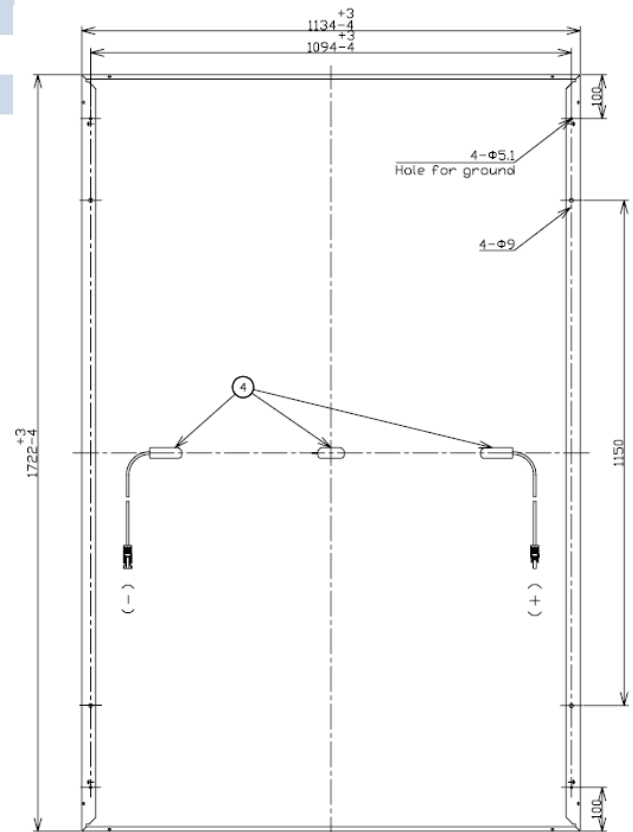

SHARP

G\ Ufd'7 cfdcfUjcb'cZ5 i ghfU]U'Dmi@X

BA 4aj * & ? S\cgSd\WBSd\ i @El † \$##% 3gefδ\{S
F7>ž#% " #% " \$2 7? 3;>, ea'Sd2 eZScbž WZSg
: a_ V6SYWZffbe,!i i i žZSdž WZSg